

September 2009

INFORMATION
TECHNOLOGY

Social Security
Administration's Data
Exchanges Support
Current Programs, but
Better Planning Is
Needed to Meet
Future Demands



GAO

Accountability * Integrity * Reliability



Highlights of [GAO-09-966](#), a report to the Chairman, Committee on Finance, U.S. Senate

Why GAO Did This Study

The Social Security Administration (SSA) receives electronic data from other agencies to support its own programs, and provides electronic data to support more than 800 state and federal agency partners. This information aids in, among other things, the processing and distribution of beneficiary payments and the delivery of services such as driver's license issuance and voter registration. SSA relies on its information technology (IT) infrastructure—its databases, applications, networks, and IT management practices—to support its current and future needs for exchanging data with its state and federal partners. GAO was asked to (1) determine the extent to which SSA's IT infrastructure effectively and efficiently supports current data exchanges, and any system-related problems affecting its exchange partners; and (2) describe SSA's efforts to ensure that its IT infrastructure can support the agency's and its partners' future data exchange environment. To do this, GAO analyzed agency documentation and interviewed SSA officials, as well as federal and state data exchange partners.

What GAO Recommends

GAO is recommending that SSA conduct the analyses needed to define requirements for delivering data exchange services to its partners in the future and use the results of these analyses to update its target architecture. In written comments on a draft of this report, SSA agreed with the recommendations.

View [GAO-09-966](#) or [key components](#). For more information, contact Valerie C. Melvin at (202) 512-6304 or melvin@gao.gov.

INFORMATION TECHNOLOGY

Social Security Administration's Data Exchanges Support Current Programs, but Better Planning Is Needed to Meet Future Demands

What GAO Found

Systems-related problems that affect SSA's ability to support outgoing data exchange programs have been few, and the agency has established effective procedures and mechanisms for addressing the problems that do occur. In this regard, SSA provides help-desk and on-site support to data exchange partners to help prevent or resolve problems, and uses procedures supported by a problem-identification and tracking system to facilitate problem resolution. State and federal partners with whom GAO held discussions stated that these efforts resulted in quick responses from SSA and effective resolution of problems that occurred. For example, a system that provides information for two data exchange programs that support driver's license issuance and voter registration in all 50 states was reported to have had almost 100 percent availability during the hours specified in the agreements governing these data exchanges. Further, all of the data exchange partners with whom GAO held discussions reported that the data that SSA provided were reliable. As a result, these partners stated that their ability to conduct business operations that depend on SSA data was not adversely affected by systems-related problems associated with SSA's IT infrastructure.

SSA and its partners anticipate that the number of requests for outgoing data exchanges will continue to increase and that the exchanges will become more complex as agencies request that these exchanges take place through online, real-time transactions. However, SSA officials stated that the agency's existing IT infrastructure may not be able to support the increased demand that they and their partners anticipate. To address overall agency needs for a more cost-effective and efficient computing environment, the agency is taking steps to modernize its computing capabilities and supporting infrastructure. For example, the agency is in the process of implementing an updated database environment and upgrading its software applications—steps that are intended to enable expanded and more efficient IT service delivery, including the electronic exchange of data. However, the agency has not fully implemented IT management practices specifically related to its outgoing data exchange environment, such as conducting thorough analyses to project the expected increase in requests for data and online access. Conducting these analyses and using this information as input to the agency's target architecture (i.e., a formal description of the agency's future environment) are important practices to clearly define future requirements to guide the direction of the agency's data exchange programs. Implementing these management practices is essential to ensuring that the agency is well positioned to meet the growing needs of its data exchange partners.

Contents

Letter		1
	Background	3
	SSA's IT Infrastructure Supports Its Current Data Exchange Environment	11
	SSA Is Taking Steps to Prepare for a Future Data Exchange Environment, but Has Not Effectively Planned for Increasing Demands for Outgoing Data	15
	Conclusions	24
	Recommendations for Executive Action	24
	Agency Comments and Our Evaluation	25
Appendix I	Objectives, Scope, and Methodology	27
Appendix II	Comments from the Social Security Administration	32
Appendix III	GAO Contact and Staff Acknowledgments	34
Tables		
	Table 1: Contents of SSA's Databases	4
	Table 2: SSA's Key Batch Application Systems Providing Data to State and Federal Partners	6
	Table 3: SSA's Key Online, Real-time Application Systems Providing Data to State and Federal Partners	7
	Table 4: Increase in the Number of Requests for SSA Data from Seven Key Data Exchange Applications, Fiscal Years 2007 to 2008	16
	Table 5: SSA Regions Reporting Requests for Online Real-Time Access to the State Online Query system	18
	Table 6: States and Agencies That We Contacted	30
Figure		
	Figure 1: SSA Databases and Key Systems That Support Outgoing Data Exchange Programs	8

Abbreviations

AAMVA	American Association of Motor Vehicle Administrators
BENDEX	Beneficiary and Earnings Data Exchange
EIEI	Electronic Information Exchange Initiative
EVS	Enumeration Verification System
FOLQ	Federal Online Query
HAVV	Help America Vote Verification
IT	information technology
MADAM	Master Data Access Method
MBR	Master Beneficiary Record
MEF	Master Earnings File
Numident	Number Holder Identification
PUPS	Prisoner Update Processing System
SDX	State Data Exchange
SOLQ	State Online Query
SSA	Social Security Administration
SSOLV	Social Security Online Verification
SSR	Supplemental Security Record
SVES	State Verification and Exchange System
UIQ	Unemployment Insurance Query

This is a work of the U.S. government and is not subject to copyright protection in the United States. The published product may be reproduced and distributed in its entirety without further permission from GAO. However, because this work may contain copyrighted images or other material, permission from the copyright holder may be necessary if you wish to reproduce this material separately.



United States Government Accountability Office
Washington, DC 20548

September 16, 2009

The Honorable Max Baucus
Chairman
Committee on Finance
United States Senate

Dear Mr. Chairman:

Through more than 3,000 agreements with federal and state agencies, the Social Security Administration (SSA) both receives incoming data to support its own programs and provides outgoing data to support state and other federal agencies' programs. Specifically:

- Information provided to SSA by other federal agencies aids in the processing and electronic disbursement of, for example, beneficiary payments or premium withholdings for entitlement programs such as the Retirement, Survivors, and Disability Insurance Program and the Supplemental Security Income Program.
- Information that SSA provides to state and other federal agencies enables more efficient processing of services such as driver's license issuance, voter registration, social services administration (such as food stamps), employment verification and eligibility, and passport issuance.

The data that SSA provides are essential to helping state and federal partners streamline operations, reduce costs, and eliminate overpayments and fraud. To carry out these transactions—over 1 billion each year—the agency relies on an information technology (IT) infrastructure consisting of the hardware, software, networks, and management practices that support capabilities to provide electronic data to and communicate with a variety of external systems belonging to the agency's data exchange partners.¹

Given the significance of the data provided by these transactions, you requested that we examine the effectiveness of the agency's IT infrastructure in supporting data exchanges that provide information to

¹In this context, the term "data exchange" refers to an ongoing mechanism for exchanging data, and the term "transaction" refers to an instance of exchanged data, such as the verification of a single Social Security number.

state and other federal agencies. Our objectives were to (1) determine the extent to which SSA's IT infrastructure effectively and efficiently supports its current data exchange programs, and describe any systems-related problems that affect the agency's state and federal data exchange partners and (2) describe SSA's efforts to ensure that its IT infrastructure can support the agency's and its partners' future data exchange environment.

As requested, we focused our study on SSA's data exchange programs that affect the ability of state and federal partners' to provide services to individuals. These data exchanges provide electronic information that is used to support state and other federal agencies' programs—that is, “outgoing” data exchanges—through the use of several components of SSA's IT infrastructure.² SSA considers these to be “non-program” data exchanges since they do not support the agency's mission.

To address both of the objectives, we identified the components of SSA's IT infrastructure that support the agency's data exchange programs, and obtained and analyzed agency documentation describing these components and SSA's data exchange operations as well as plans to make improvements to the agency's IT infrastructure. We interviewed SSA officials, including two regional office data exchange coordinators from New York City and Kansas City,³ as well as officials of selected state and federal data exchange partners, to obtain their views on the effectiveness of SSA's IT infrastructure in supporting data exchanges and on the agency's plans for improvements. We spoke with and collected documentation from partners who represent various state agencies in New York, California, Idaho, North Carolina, and Iowa, and from federal data exchange partners within the Departments of Veterans Affairs, State, Homeland Security, and Health and Human Services. We determined that the data provided by SSA about the agency's data exchange IT infrastructure were sufficiently reliable for the purposes of our

²SSA also provides information, such as Social Security number verification, to other external entities, such as private companies. The scope of this study did not include those partners. We also did not include exchanges from SSA to the Department of the Treasury in the scope of our study because these administrative exchanges are conducted so that Treasury can provide payments (through checks and electronic transfers) to beneficiaries on behalf of SSA; these exchanges do not support Treasury programs.

³We held discussions with these two region coordinators based on the extent of their experiences with data exchanges and the number of data exchange programs that they support. The New York City region includes New York, New Jersey, Puerto Rico, and the U.S. Virgin Islands; the Kansas City region includes Kansas, Missouri, Iowa, and Nebraska.

engagement. Appendix I contains more details on our objectives, scope, and methodology.

We conducted this performance audit from December 2008 to September 2009 at SSA's headquarters in Baltimore, Maryland. We also met with state agency officials in New York, California, Idaho, North Carolina, and Iowa and with federal agency officials with the Departments of Veteran Affairs, State, Homeland Security, and Health and Human Services in Washington, D.C. We conducted our work in accordance with generally accepted government auditing standards. Those standards require that we plan and perform the audit to obtain sufficient, appropriate evidence to provide a reasonable basis for our findings and conclusions based on our audit objectives. We believe that the evidence obtained provides a reasonable basis for our findings and conclusions based on our audit objectives.

Background

SSA currently maintains over 800 agreements that support exchanges through which the agency provides data to state and federal partners (approximately 700 state and almost 100 federal agency partners). These agreements define the requirements, terms, and conditions under which the data will be provided to the partners. In many cases, legislation mandates the agency to provide electronic data in support of certain programs.⁴ For example, SSA is required to provide data to the Veterans Benefits Administration, which is part of the Department of Veterans Affairs, in support of the Veterans Benefits Administration's efforts to determine benefits eligibility. In other cases, SSA voluntarily enters into data exchange agreements with state and other federal agency partners.

IT Infrastructure Components Supporting SSA Data Exchanges

SSA's existing IT infrastructure—databases, applications, networks, and management practices—supports the agency's daily operations and core mission activities, such as administering monthly Retirement, Survivors, and Disability Insurance and Supplemental Security Income benefits, as well as its data exchange programs.⁵ Data provided to SSA's data

⁴According to SSA, of the over 800 agreements with state and federal partners, about 530 are legislatively mandated to support programs such as veterans' and Medicare benefits administration, voter registration, and employment eligibility verifications.

⁵SSA's core mission is to administer the Retirement, Survivors, and Disability Insurance program, which provides benefits to workers who have paid into the Social Security trust fund, and the Supplemental Security Income program, which provides or supplements the income of aged, blind, or disabled individuals with limited income and resources.

exchange partners are accessed from the same database infrastructure that supports the agency's overall operations and mission. This infrastructure includes several databases that store and maintain beneficiary data related to SSA's benefits programs. These databases are briefly described in table 1.

Table 1: Contents of SSA's Databases

Database	Contents
Master Beneficiary Record (MBR)	All data related to Retirement, Survivors, and Disability Insurance benefits enrollment and contributions
Master Earnings File (MEF)	Wage data reported by employers for their employees
Supplemental Security Record (SSR)	Data about Supplemental Security Income eligibility and payments
Number Holder Identification (Numident)	Social Security number holders' name, date of birth, place of birth, parents' names, citizenship status at the time of application, date of death (if applicable), and the office where the Social Security number application was processed and approved
Prisoner database	Prisoner confinement information that various prisons report to SSA

Source: GAO analysis of SSA data.

Among the databases, the Master Beneficiary Record, Master Earnings File, and Supplemental Security Record databases are included in the agency's legacy database infrastructure, referred to as the Master Data Access Method, or MADAM. The Number Holder Identification database has recently been updated to a more modern system based on commercially available software.⁶

SSA also maintains various application systems that were designed and developed specifically to process data exchange transactions and that generally support multiple data exchanges. These applications provide Social Security number matching and verification information that supports various types of federal and state programs, such as driver's license issuance, voter registration, social services administration (e.g., food stamps), employment eligibility verification, and passport issuance.

⁶The Prisoner database is a separate database that resides outside of the MADAM infrastructure.

The applications accept requests for information from SSA's partners, retrieve and attempt to match or verify data from the databases against the information submitted by the partners, and then transmit responses—that is, the results of the data matching and verification—to the data exchange partners who initiated the requests. The applications primarily match Social Security number, name, and date-of-birth information submitted by the partners against data stored in the databases. The request transactions are processed and the responses provided through the use of either batch file or online, real-time processing.⁷

SSA relies on 11 key application systems to process information requests from and provide response data to its state and federal data exchange partners. These data exchange applications provide data to programs associated with 582 of the state-level agreements and 26 of the federal-level agreements—about 75 percent of the outgoing data exchange agreements that the agency supports.⁸ These 11 key data exchange application systems process over 1 billion transactions annually.

Six of the 11 applications process transaction requests and responses in batch mode. That is, they return single files that contain matching or verification information in response to multiple transaction requests (i.e., a “batch”). The majority of SSA's state and federal data exchange partners receive transaction responses from the agency in batch files. Table 2 describes these batch processing application systems.

⁷Batch transaction processing sequentially matches data files containing one or more data items against records in SSA's databases and returns responses to multiple requests for data in one file at a scheduled time. Online, real-time processes return responses to individual requests for data at the time that the requests are made.

⁸The remaining 25 percent of SSA's outgoing data exchange agreements are supported by various applications that provide data to several different state and federal agencies. For example, one such application was developed to provide all states with information to identify individuals who may be eligible for Medicaid continuation following a Retirement, Survivors, and Disability Insurance cost-of-living adjustment.

Table 2: SSA’s Key Batch Application Systems Providing Data to State and Federal Partners

System	Function	Databases accessed	Number of data exchange agreements
State Verification and Exchange System (SVES)	Provides verification of Social Security numbers and benefits information used to establish eligibility for income and health maintenance programs. The system allows users to request data from other SSA data exchange applications. In these cases, SVES filters the requesting transactions to determine the appropriate applications for processing. SVES then passes the requests to the applications, which process the requests and return responses to the partners.	<ul style="list-style-type: none"> • Master Beneficiary Record • Supplemental Security Record • Number Holder Identification 	214 state, territory, and District of Columbia, and 5 federal agency agreements
Beneficiary and Earnings Data Exchange (BENDEX)	Provides Retirement, Survivors, and Disability Insurance benefit information to states and territories, and provides earnings and employer data for the last calendar year.	<ul style="list-style-type: none"> • Master Beneficiary Record • Master Earnings File 	96 state, territory, and District of Columbia agency agreements
Prisoner Update Processing System (PUPS)	Provides prisoner record information to federal and state agencies to establish eligibility or ineligibility for various programs.	<ul style="list-style-type: none"> • Prisoner database 	Included in SVES agreements
Earnings System	Provides earnings information and Social Security information to federal, state, or local agencies for the purpose of validating Social Security numbers used in administering cash or noncash income maintenance programs or health maintenance programs, and provides information to employers or former employers for correcting or reconstructing earnings records for Social Security tax purposes.	<ul style="list-style-type: none"> • Master Earnings File 	4 federal agency agreements
State Data Exchange (SDX)	Provides Supplemental Security Income data to states for administering income maintenance or health maintenance programs, such as state supplementation, interim assistance payments, and Medicaid.	<ul style="list-style-type: none"> • Supplemental Security Record 	51 state, territory, and District of Columbia agency agreements
Enumeration Verification System (EVS)	Provides Social Security number verifications to several partners, including employers and federal and state benefits-paying agencies for a number of purposes, such as processing individuals’ applications for welfare benefits.	<ul style="list-style-type: none"> • Number Holder Identification 	33 state, 15 federal, and District of Columbia agency agreements

Source: GAO analysis of SSA data.

Of the 11 key data exchange application systems, 5 process transaction requests and responses in online, real-time mode. These systems retrieve data from SSA’s databases in several ways. For example, using online, real-time processing, a state partner can initiate a query transaction from within a state system. The query is transmitted to SSA systems via various transmission mechanisms, such as dedicated lines or Internet connections,

which process the query and then provide an immediate, or real-time, response to the requester. In other cases, employees of some federal agencies are allowed to remotely log on to SSA systems and execute online database inquiry transactions, to which they receive a real-time response. Table 3 shows the key application systems that support online data exchange transactions.

Table 3: SSA’s Key Online, Real-time Application Systems Providing Data to State and Federal Partners

System	Function	Databases accessed	Number of data exchange agreements
State Online Query (SOLQ)/Federal Online Query (FOLQ) ^a	Provides verifications of Social Security numbers and benefits information to both state and federal partners to establish eligibility for income and health maintenance programs.	<ul style="list-style-type: none"> • Master Beneficiary Record • Supplemental Security Record • Number Holder Identification 	48 state and 2 federal agency agreements
Unemployment Insurance Query (UIQ)	Provides Social Security number verification and Social Security benefit information that are used by state unemployment insurance representatives to offset unemployment payments with the receipt of SSA payments. The Unemployment Insurance Query is part of SOLQ.	<ul style="list-style-type: none"> • Master Beneficiary Record • Number Holder Identification 	36 state agency agreements
E-Verify	Provides confirmation or nonconfirmation of newly hired employees’ Social Security numbers to aid employers in verifying employment eligibility under the E-Verify program administered by the Department of Homeland Security.	<ul style="list-style-type: none"> • Number Holder Identification 	1 federal agency agreement
Social Security Online Verification (SSOLV)	Provides Social Security number verification primarily to state motor vehicle agencies for the issuance of driver’s licenses and state identification cards, through the American Association of Motor Vehicle Administrators (AAMVA) network. ^b	<ul style="list-style-type: none"> • Number Holder Identification 	52 state, territory, and District of Columbia agency agreements
Help America Vote Verification (HAVV)	Provides to AAMVA verifications of the last four digits of Social Security numbers of voter registrants who do not have driver’s licenses for use by state AAMVA partners to register new voters.	<ul style="list-style-type: none"> • Number Holder Identification 	45 state, territory, and District of Columbia agency agreements

Source: GAO analysis of SSA data.

^aWhen the system is used to provide data to federal partners, it is referred to as Federal Online Query. The SOLQ/FOLQ application is an online version of the batch application State Verification and Exchange System.

^bThe AAMVA network serves as the conduit for transmitting verification requests from individual state driver’s licensing agencies to SSA, as well as receiving verification responses from SSA and transmitting them to individual states.

Figure 1 provides an overview of the databases and application systems, and the data flow between them and the agency's state and federal partners.

Figure 1: SSA Databases and Key Systems That Support Outgoing Data Exchange Programs

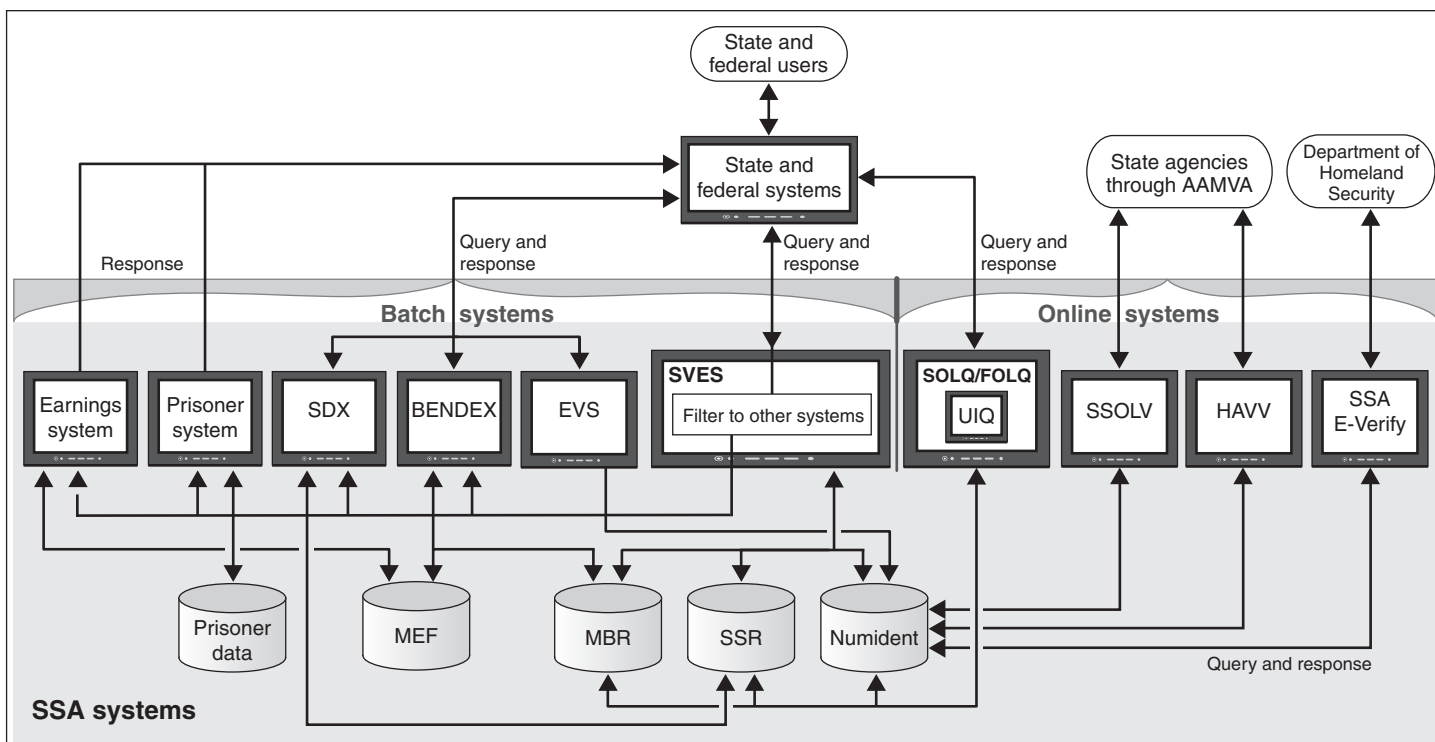

Source: GAO analysis of SSA data.

Note: Tables 1, 2, and 3 of this report provide the definitions of abbreviations and acronyms and descriptions of systems and databases.

Funding and Management of SSA's Outgoing Data Exchange Programs

SSA's outgoing data exchange programs are funded through various sources. These include the agency's annual budget and reimbursements from the data exchange partners, which are established through the data exchange agreement process. For example, the agreement between SSA and the Veterans Benefits Administration states that SSA will provide data at no cost. In this case, SSA's annual budget provides funds to support the administrative and systems-related activities that are required to support this agreement, such as the development of agreements and technical support for the data exchange partners. SSA receives reimbursements from a number of its external partners, including the American

Association of Motor Vehicle Administrators (AAMVA)⁹ along with 2 state agencies and 14 other federal agencies, for data exchanges. For example, according to agency documentation, SSA's agreement with AAMVA to provide electronic Social Security number verifications to all states for processing driver's license applications resulted in reimbursements in the amount of \$230,882 to the agency in 2007. The amounts of reimbursements, if any, are determined on the basis of provisions established by the agreements with each data exchange partner. For 364 of these agreements, SSA provides electronic data at no cost to state and federal partners.¹⁰

According to agency documentation, during fiscal year 2007, SSA received about \$10 million in total reimbursements for its outgoing data exchanges, primarily from federal data exchange partners. The documentation indicates that about half of this amount was reimbursed on the basis of agreements with the Departments of Homeland Security and Health and Human Services.

The management and oversight of SSA's data exchange programs span multiple agency components. Among these, the Associate Commissioner for the Office of Earnings, Enumeration and Administrative Systems, has primary responsibility for systems activities related to SSA's data exchange programs, and the Office of Budget, Finance, and Management, Office of Strategic Services has primary responsibility for data exchange agreements.

Prior GAO Reports on SSA's IT Management Practices

We have previously reported on SSA's IT management practices and challenges. Most recently, we studied and reported on the agency's ability to effectively deliver services, including those related to electronic data exchanges. In our reports, we made recommendations directed toward the agency's need to strengthen its plans for delivering services to

⁹AAMVA reimburses SSA for data exchange services for all 53 partners: 50 states, 2 territories, and the District of Columbia.

¹⁰Data exchange agreements with partners are established for varying timeframes. For example, many non-reimbursable agreements are generally established for an 18-month timeframe with 12-month renewal. Reimbursable agreements, such as those with AAMVA, are generally established for 5 years, with annual financial commitment agreements.

beneficiaries and to address challenges associated with a growing and increasingly complex data exchange environment.¹¹

In December 2008, we reported specifically on SSA's data exchange environment and identified challenges that the agency faced in supporting data exchange programs.¹² Among these, we noted that the agency faced challenges in retaining the expertise needed and maintaining the technology required to support an adequate technical infrastructure to meet future needs. We also described an agency initiative to study ways to better manage the data exchange environment and address current and future challenges and limitations. This initiative identified actions that the agency should take to address challenges related to management and systems-related issues. We recommended in our report that SSA set milestones for undertaking these actions. The Commissioner of Social Security concurred with our recommendation and stated that the agency had established milestones for taking action.

Also in January 2009, we reported that increases in retirement and disability filings, along with ongoing and expected increases in retirements of SSA's most experienced staff, posed difficult challenges for the agency in meeting future service delivery needs. We recommended that the agency take steps to address these challenges and develop a plan that describes how it will deliver quality service in the future while managing growing work demands and constrained resources.¹³ In response, SSA stated that it had intensive planning efforts in place, but agreed to develop a single planning document that would describe service delivery and staffing plans.

¹¹We have also reported on SSA's implementation of IT management practices, including the definition of an enterprise architecture and IT investment management. See GAO, *Information Technology: SSA Has Taken Key Steps for Managing Its Investments, but Needs to Strengthen Oversight and Fully Define Policies and Procedures*, [GAO-08-1020](#) (Washington, D.C.: Sept. 12, 2008); and *Enterprise Architecture: Leadership Remains Key to Establishing and Leveraging Architectures for Organizational Transformation*, [GAO-06-831](#) (Washington, D.C.: Aug. 14, 2006).

¹²GAO, *Information Technology: Demand for the Social Security Administration's Electronic Data Exchanges Is Growing and Presents Future Challenges*, [GAO-09-126](#) (Washington, D.C.: Dec. 4, 2008).

¹³GAO, *Social Security Administration: Service Delivery Plan Needed to Address Baby Boom Retirement Challenges*, [GAO-09-24](#) (Washington, D.C.: Jan. 9, 2009).

SSA's IT Infrastructure Supports Its Current Data Exchange Environment

SSA has implemented technology and procedures within its existing IT infrastructure to support its current data exchange environment, including processes to identify, track, and resolve systems-related problems. Those data exchange partners we included in our study¹⁴ indicated that the agency's IT infrastructure had effectively supported the exchanges in which they participate. The partners reported that they had experienced few systems-related problems and none that had a significant impact on their ability to conduct business.

SSA Has Established Practices and Procedures for Supporting Data Exchange Services

An effective IT infrastructure provides performance capabilities, such as system availability and reliable data, that are essential to enabling the efficient and economical exchange of electronic data.¹⁵ The Software Engineering Institute defines practices for providing effective IT services, including those that are key to an agency's ability to ensure that its infrastructure supports business operations.¹⁶ These practices include, among other things, the establishment of (1) monitoring capabilities to proactively identify problems; (2) help desks to collect information on incidents and initiate problem-solving actions; and (3) capabilities to prioritize incidents, track the status and progress of incident resolution, and validate the complete resolution of incidents. By implementing practices to monitor, track, and resolve systems-related problems, agencies can reduce the risk that when problems occur, their information systems and support mechanisms will fall short of effectively supporting business operations and service commitments.

To ensure that SSA's IT infrastructure meets the performance requirements of the agency's data exchange partners, SSA and its partners establish, through data exchange agreements, specific and detailed performance standards (e.g., system availability, scheduled outages, data accuracy, and response times for each exchange, along with protocols for

¹⁴These partners represented various state agencies in New York, California, Idaho, North Carolina, and Iowa, and federal data exchange partners within the Departments of Veterans Affairs, State, Homeland Security, and Health and Human Services. See appendix I for more details.

¹⁵GAO, *Executive Guide: Measuring Performance and Demonstrating Results of Information Technology Investments*, GAO/AIMD-98-89 (Washington, D.C.: Mar. 1, 1998).

¹⁶Software Engineering Institute, *CMMI for Services, Version 1.2* (Pittsburgh, Pa.: February 2009). The Software Engineering Institute is a nationally recognized, federally funded research and development center established at Carnegie Mellon University to address software engineering practices.

reporting and resolving systems-related problems). These elements are critical to an effective IT infrastructure that enables the efficient and economical exchange of electronic data.¹⁷ For example:

- The data exchange agreement with AAMVA specifies that SSA will provide responses for 95 percent of all Social Security Online Verification system requests received from AAMVA within 3 seconds or less and that responses to 99 percent of requests will be provided within 5 seconds or less. The agreement also defines the hours of system availability and scheduled outages.
- The data exchange agreement with the Veterans Benefits Administration specifies that SSA is to provide a 99 percent data accuracy rate in support of the administration of veterans' benefits.

To address any systems-related problems that might occur and affect its data exchange partners, SSA has implemented several key practices for providing effective IT services, as defined by the Software Engineering Institute. Specifically, the agency has established processes to identify, track, and resolve systems-related problems. For example, the agency established a national help desk for responding to systems-related problems, and employs a process for recording, prioritizing, tracking, and solving IT problems. This process is supported by the Change Asset and Problem Reporting System, which is a system that is used agencywide to prioritize systems-related problems, track the status and progress of resolutions, and validate the resolution of problems. System reports from January 2008 to February 2009 identified approximately 35 systems-related problems that affected data exchanges. These problems were primarily temporary outages lasting less than 1 minute, including several problems lasting just seconds.

Additionally, network support personnel proactively monitor data exchange components through the agency's full-time (24 hours a day, 7 days a week) network operations and monitoring centers, which provide support for agencywide IT infrastructure components. Other SSA support staff also regularly monitor systems resource usage and work with state and federal partners to help resolve problems as they occur. For example, according to SSA officials, if a partner notifies the agency of slow response time, support staff members monitor the partner site's bandwidth usage

¹⁷[GAO/AIMD-98-89](#).

and make upgrades as necessary. SSA has established other specific procedures for speedy response to resolve systems-related problems. For example, according to AAMVA partners, SSA's network operations and monitoring centers are responsible for monitoring the performance of the data exchange system that is used to support driver's license issuance and voter registration (the Social Security On-Line Verification system). When SSA personnel at the centers receive an alert indicating that the system is not performing properly, they investigate the problem and assign responsibility for resolving the problem to the appropriate SSA unit. Responsible personnel then notify AAMVA of the problem and the status of the resolution process, which is updated through the Change Asset and Problem Reporting System. Reports from the reporting system show that, in one case of a system outage, SSA support staff resolved the problem in 34 seconds by moving the AAMVA network connection to a backup system.

SSA Has Effectively Provided Data to Support Partners' Business Operations

All of the federal and state data exchange partners included in our study stated that SSA's IT infrastructure adequately supported the performance standards established by existing agreements and effectively provided data that supported their business operations. They agreed that SSA was responsive and quickly resolved problems when they did occur and stated that, as a result of SSA's efforts, their ability to conduct business operations that depend on data provided by the agency had not been adversely affected by systems-related problems associated with SSA's IT infrastructure. These partners, which had been receiving electronic data from SSA for 2 to more than 30 years, reported that they experienced no or only minor systems-related problems caused by SSA's IT infrastructure. For example:

- AAMVA partners reported that the SSA system that supports their data exchange historically was fully available during the hours of system availability specified in their exchange agreement. According to these officials, the system experienced virtually no downtime through calendar year 2008—it was operational 99.8 percent of the time that the system was available.
- Officials with Idaho's Departments of Labor and Transportation told us that SSA's problem resolution procedures and support staff were effective and provided ample support and timely response to reported problems. These officials added that while 4 percent of Social Security number verification responses that they received from SSA via the AAMVA system were not confirmed, these nonverifications were predominantly caused by

name changes that were not updated by the Social Security number holders (e.g., changes from maiden names to married names), rather than by problems with SSA's data exchange systems or data.

- Officials with the Iowa state agencies stated that SSA's systems performance was satisfactory. Specifically, officials with the state's Department of Transportation, which receives data through the AAMVA network, reported that although they occasionally experienced unscheduled outages and slow system response times, SSA's overall performance was satisfactory. Officials with the state's Department of Human Services said that they had not experienced any problems.
- Officials with the eight California agencies included in our study reported no problems associated with SSA's data exchange systems.¹⁸

Beyond these reports, the two SSA regional office data exchange coordinators with whom we spoke stated that state and territory agency partners within their regions, New York City and Kansas City,¹⁹ had not reported systems-related problems associated with SSA's existing IT infrastructure. Specifically, the Kansas City coordinator stated that the region had not reported any problems with data exchange systems since the coordinator came on board in September 2008.

Similarly, the federal data exchange partners with whom we met did not report any problems associated with SSA's IT infrastructure that negatively affected their ability to carry out business operations. For example:

¹⁸The eight California agencies are the State Controller's Office, Employment Development Department, Franchise Tax Board, Health Care Services, Social Services, Board of Equalization, Department of Motor Vehicles, and Child Support Services.

¹⁹SSA's New York region includes New York, New Jersey, Puerto Rico, and the U.S. Virgin Islands, and the Kansas region includes Kansas, Missouri, Iowa, and Nebraska.

-
- Data exchange officials with the Department of Homeland Security reported as of June 2009 that no systems-related problems had affected their ability to conduct business.²⁰
 - Veterans Benefits Administration and Veterans Health Administration officials also stated that SSA's IT infrastructure was effective in delivering data that supported their benefits administration programs and that they had experienced no problems with the quality or delivery of data from SSA's systems.
 - Officials with the Centers for Medicare and Medicaid Services stated that they occasionally experienced late delivery of files that delayed the processing of Medicare entitlement information. However, these officials described this matter as a situation that they considered to be within the norm, given the very large amounts of data that are being exchanged between systems. These partners did not view these occasional late deliveries to be a significant issue with the SSA systems that provided data.

SSA Is Taking Steps to Prepare for a Future Data Exchange Environment, but Has Not Effectively Planned for Increasing Demands for Outgoing Data

Although SSA's existing IT infrastructure is sufficient to support current outgoing data exchanges, SSA officials and the agency's partners anticipate that the number of these exchanges will continue to increase and become more complex, placing greater demands on the infrastructure and systems. To address overall agency needs for a more cost-effective and efficient computing environment, SSA is currently taking steps to modernize its IT infrastructure, including components that support its data exchange programs. For example, the agency is updating its 30-year-old database infrastructure, converting outdated software applications, and expanding its physical data processing capacity. However, the agency has not established and executed IT management practices needed to effectively guide and oversee the direction of its outgoing electronic data exchange programs, such as conducting the analyses required to project future workload needs and performance requirements—information that is essential to developing a target architecture that identifies business and

²⁰At the conclusion of our study in September 2009, the Department of Homeland Security reported that, since our initial discussions in June 2009, the department had experienced two extended outages related to SSA's E-Verify system when the direct line between SSA and the Department of Homeland Security failed. The outages prevented the department from completing E-Verify queries. According to department officials, SSA addressed the problem and has plans to implement enhancements intended to prevent the loss of data if the direct lines fail in the future.

technical requirements for a future data exchange environment. If these analyses are not completed, SSA's ability to provide and maintain an IT infrastructure that meets requirements to effectively support its data exchange programs in the future could be at risk.

SSA and Partners Anticipate Increased Demand for Data Exchanges

Based on recent increased numbers of requests for data provided by data exchange services, both SSA and its data exchange partners anticipate that the agency's outgoing data exchange programs will continue to grow and will outpace current capabilities. SSA reported that from fiscal years 2007 to 2008, the number of data requests made to seven of SSA's key data exchange applications increased from 1.19 billion to 1.37 billion, or about 15 percent. Table 4 shows details of the increase in data requests for these applications.

Table 4: Increase in the Number of Requests for SSA Data from Seven Key Data Exchange Applications, Fiscal Years 2007 to 2008

System	Description	Number of data requests, by fiscal year (in millions)	
		2007	2008
EVS	Batch verifications other than for Social Security numbers, and for non-SVES users (up to 250,000 numbers per requester per file)	377.3	451.4
	Social Security number batch verifications through EVS	62.6	88.7
	SVES batch verifications through EVS	497.8	542.2
E-Verify	Online, real-time verifications for employers via Department of Homeland Security	3.3	6.7
SSOLV	Online, real-time verifications for state motor vehicle departments via AAMVA	18.3	20.2
HAVV	Online, real-time verifications for voter registration via AAMVA	2.3	7.7
SOLQ/ FOLQ	Online, real-time verifications for federal and state agencies (includes UIQ)	32.8	41.3
BENDEX	Benefit Information to the states	157.8 (starting February 2007)	180.0
SDX	State Data Exchange—Daily File	38.4	30.0
Total		1.19 billion	1.37 billion

Source: SSA.

Note: Tables 1, 2, and 3 of this report provide the definitions of system abbreviations.

An example of one data exchange application that has been required to process large increases in data requests for Social Security number confirmations is SSA's E-Verify application. This application supports the

Department of Homeland Security E-Verify program, which is used to help employers verify the employment eligibility of newly hired workers.²¹ Participation in the program has been voluntary at the private and state levels since its implementation 10 years ago and, since then, utilization of SSA's E-Verify application has increased dramatically. In the past 2 years alone, usage has doubled twice. Further, federal legislation has been proposed to, among other things, require the use of the E-Verify program by employers across the nation. If such legislation is enacted, agency officials estimate that the number of queries to E-Verify could quickly surpass 60 million per year—nearly 10 times the number of requests in fiscal year 2008.

SSA and Partners Anticipate Expanded Need for Online Access to Data Exchange Systems

In addition to growth in the numbers of data exchange requests, the complexity of the exchanges is expected to increase, in that agencies are increasingly asking for online access (a more complex requirement than batch access). Officials from four of the state and federal agencies with whom we spoke stated that their needs for online access to SSA's data exchange systems are expanding. For example, officials with New York, Idaho, and California reported that their programs will need expanded online access to SSA's data exchange systems to support increasing workloads and to provide more efficient processing of data requests. Specifically, officials with New York's Office of Temporary and Disability Assistance explained that their programs will be requiring increased online or Web-based service from SSA in the future to support expected general workload growth as their need for Social Security number verifications and other SSA information grows. Officials with California's Department of Child Support Services stated that online access is needed to improve efficiencies in caseworkers' ability to verify benefits, schedule court hearings to determine amounts of child support payments, and process and close eligible cases. Officials with Idaho's Department of Labor also projected that they would need more online access to SSA's data exchange systems through Web-based transaction processing to support more efficient case processing and access to SSA's data exchange systems 24 hours a day, 7 days a week.

²¹The Department of Homeland Security's employment verification program, also called E-Verify, is used by employers to verify employment eligibility. Employers query the Department of Homeland Security's E-Verify Web site for information, which then requests Social Security confirmation from SSA's E-Verify application system. The data exchange this report describes is between the two departments' systems—that is, SSA's outgoing exchange that provides information to the Department of Homeland Security's system.

In 2008, SSA officials polled the agency's 10 regional offices to identify current data exchange partners that had requested online, real-time access to the agency's State Online Query system over the previous 24 months.²² The poll identified state partners in 8 of the regions that had made such requests.²³ Table 5 shows these regions along with the 24 state agencies that had requested online access for their programs (in addition to the 50 partners that already had access to the State Online Query system).

Table 5: SSA Regions Reporting Requests for Online Real-Time Access to the State Online Query system

SSA region	State	Agencies and programs
Boston	Rhode Island	<ul style="list-style-type: none"> Department of Labor Temporary Disability Insurance and Worker's Compensation
Philadelphia	Virginia	<ul style="list-style-type: none"> Department of Medical Assistance Services
New York	New York	<ul style="list-style-type: none"> Human Services Organizations, including: <ul style="list-style-type: none"> Child Support Enforcement State Children's Health Insurance Program and state health programs Home Energy Assistance Foster Care and Adoption Prescription coverage for the elderly Lifeline state-funded, low cost telephone service
	New Jersey	<ul style="list-style-type: none"> Human Services Organizations, including: <ul style="list-style-type: none"> Foster Care and Adoption Home Energy Assistance State Children's Health Insurance Program and state health programs Commission for the Blind and Visually Handicapped
Chicago	Illinois	<ul style="list-style-type: none"> Department of Human Services' Division of Vocational Rehabilitation Services
	Michigan	<ul style="list-style-type: none"> Workers' Compensation Agency
Dallas	Arkansas	<ul style="list-style-type: none"> Department of Human Services' Foster Care Program
Denver	Wyoming	<ul style="list-style-type: none"> Department of Human Services' State Child Protection Services
San Francisco	California	<ul style="list-style-type: none"> Department of Health and Human Services for county General Assistance programs

²²SSA's current policy limits access to the State Online Query system to Temporary Assistance to Needy Families and Medicaid agencies. This decision was made by the SSA's Acting Commissioner in February 2001.

²³The Atlanta and Kansas regional offices did not identify any partners that had requested State Online Query access.

SSA region	State	Agencies and programs
Seattle	Washington	<ul style="list-style-type: none"> • Department of Labor and Workforce Development for Vocational Rehabilitation Program and Workers Compensation Program • Department of Health and Welfare for Vocational Rehabilitation Program, Child Welfare Programs, State Payment Accuracy, Aging and Disability Services, Welfare Fraud, Institutional Revenue, Overpayment Writing Unit • Tribal Entities for Temporary Assistance for Needy Families, Food Stamps, Medicaid • Department of Services for the Blind for Blind and Visually Impaired Services and Programs, Vocational Rehabilitation Program • Youth Authority for Temporary Assistance for Needy Families, Food Stamps, Medicaid • Vocational Rehabilitation Commission for Vocational Rehabilitation Services • Public Utility Commission for Utility Assistance Program

Source: SSA.

SSA Is Taking Steps to Modernize Its IT Infrastructure, but It Has Not Effectively Planned for Increasing Demands on Its Outgoing Data Exchange Programs

Office of Management and Budget Circular A-130 and industry best practices stress the importance of agencies taking advantage of cost-effective technology to improve operations.²⁴ Additionally, industry studies have shown that modern technology can offer organizations more efficient and effective automation capabilities to meet service delivery demands. Further, more advanced technology is important to support online, real-time transaction processing, which is more demanding than batch processing due to the need for increased systems availability and more sophisticated technology.²⁵

SSA officials are taking steps to update key components of the agency's IT infrastructure, including those that directly support its data exchange services, to provide expanded and extended processing capabilities. In particular, the agency is in the process of modernizing the agency's database infrastructure, upgrading software, and building new data centers.

²⁴Office of Management and Budget Circular A-130, *Management of Federal Information Resources*; and [GAO/AIMD 98-89](#).

²⁵Specifically, online real-time processing requires full-time system availability (24 hours a day, 7 days a week) and technology, such as Web-based software, that enables direct, online access to computing services and the ability to respond to data requests as soon as they are received. In contrast, batch processing transactions are processed at scheduled intervals and transmit all responses to requests for data at the same scheduled time.

According to an SSA Senior Enterprise Architect, the agency's legacy database infrastructure—MADAM—was created in-house in the early 1980s and, over time, became outdated and difficult to support, limiting the agency's ability to provide expanded data processing services.²⁶ For example, the MADAM databases must be backed up and maintained daily and are not available during the time that maintenance occurs. This down time prevents the agency from providing complete data processing services 24 hours a day, 7 days a week to support the agency's core mission and operations as well as its data exchange programs.²⁷

Thus, SSA is in the process of converting its MADAM environment to a modern and commercially available system that is intended to support online processing 24 hours a day, 7 days a week. According to SSA officials, the agency has already converted its Numident database, and plans to convert its Master Earnings File, Supplemental Security Record, and Master Beneficiary Record databases in 2009, 2011, and 2012, respectively. Further, SSA is in the process of updating its E-Verify data exchange operating environment. In this regard, the agency is implementing an environment in which E-Verify data requests will be processed against a dedicated database and will provide continuity of operations and disaster recovery capabilities, which are currently not available. These upgrades are intended to support the projected increase in demand for E-Verify services and reduce the risks of system slowdowns and disruptions. The E-Verify upgrades are expected to be completed and implemented in August 2009.

The agency is also upgrading its current systems environment, including the systems that support data exchanges. This environment contains aging software that is based on about 36 million lines of COBOL code, a programming language that is generally viewed as obsolete and that makes it difficult to implement new business processes and new service delivery models, such as online, real-time processing. According to SSA officials, the agency is upgrading its software applications to Web-based technology

²⁶The MADAM databases include the Master Earnings File, Supplemental Security Record, and Master Beneficiary Record databases.

²⁷According to SSA officials, the agency's MADAM databases accept traffic during this down time, even if the data processing systems themselves are unavailable. These data requests are held, then processed when the systems become available. In this regard, the legacy database environment is available 24 hours a day, 7 days a week, but is not able to complete data processing transactions during maintenance down time.

that is intended to better enable online, real-time access to data processing services.

Further, SSA has recently built a new data center to provide expanded data processing capacity in addition to that provided by its National Computer Center. The agency also has plans to replace the 30-year-old National Computer Center to, according to SSA officials, provide more efficient and economical processing capabilities and support growing requirements of a full-time electronic service delivery operation.²⁸ By taking these steps to modernize its agencywide IT infrastructure, including components that support data exchange programs, SSA is aiming to provide the computing capabilities needed to support increasing and future demands for electronic data exchange services.

SSA's IT strategic plan reflects the priorities that are intended to guide the agency's operational and tactical IT planning through fiscal year 2012.²⁹ Regarding data exchanges, the plan discusses an agency initiative that is intended to study various data exchanges and ways to allow partners to link more efficiently to the agency's systems. Also, the agency's IT vision document³⁰ describes plans to replace various methods of sharing data with an easy-to-use, Web-based portal that provides data to partners through a menu-driven system, along with a plan to use a single registration process and a secure, controlled environment that ensures data are protected. The vision document identifies as a key initiative the need to maintain a robust data exchange architecture that fully supports the growing demand for information sharing.

Even as SSA proceeds with planned updates to its IT infrastructure, the agency has not fully implemented IT management practices that are essential to help guide its direction related to data exchanges. Sound management practices require organizations to perform the necessary planning for investments to ensure that they effectively support current and future business needs, such as a more demanding data exchange

²⁸Provisions of the American Recovery and Reinvestment Act of 2009 made available \$500 million for SSA's replacement of the National Computer Center and for associated IT costs.

²⁹Social Security Administration, *Social Security Information Resources Management Strategic Plan, Fiscal Year 2007*.

³⁰Social Security Administration, *Information Technology Vision: 2009–2014*.

environment.³¹ In planning for future business operations, agencies should also, among other things, project their programs' anticipated workloads, such as increases in data requests and transaction volumes—information that is essential for making informed decisions concerning workload management and the technological solutions needed to sustain efficient and effective performance in the future.³² Further, this information can provide critical input to the agency's planning efforts, including the development of a target architecture.

Nevertheless, according to agency officials, SSA has not conducted detailed analyses to project future workload requirements resulting from the increasing demand and expanded need for outgoing electronic data exchanges. Specifically, the agency has not projected increases in the number of requests for data or the need for more online, real-time access to its data exchange systems. The agency's Director of the Division of Information, Verification and Exchange Services and the Director of the Office of Systems Security Operations Management maintain that the agency's tactical plans for delivering electronic services will be sufficient to address future needs for data exchanges. However, these plans have not yet been developed. Further, while the agency's strategic direction and vision for its data exchange environment are important, they do not substitute for the more detailed analysis that is essential to identifying the specific business and technical requirements for its data exchange programs and partners.

Moreover, in the absence of such detailed analysis, SSA cannot be assured that it will achieve the robust data exchange architecture that it envisions. According to federal guidance, an agency should develop an enterprise architecture, or modernization blueprint, that describes in both business and technology terms how it operates today and how it intends to operate and support projected needs in the future—that is, its target architecture.³³ Federal guidance states that enterprise architectures should identify the data that are to be exchanged, the frequency and nature of the exchanges,

³¹OMB Circular No. A-130 and *Planning, Budgeting, Acquisition, and Management of Capital Assets*, Circular No. A-11, Part 7 (Washington, D.C.: July 2003).

³²GAO, *Assessing Risks and Returns: A Guide for Evaluating Federal Agencies' IT Investment Decision-making*, [GAO/AIMD-10.1.13](#) (Washington, D.C.: February 1997); Software Engineering Institute, *CMMI for Services, Version 1.2*.

³³OMB Circular A-130.

and the business processes supported by the data exchanges.³⁴ For SSA to ensure that its target architecture provides for a future IT infrastructure that will support its expanding data exchange environment, the agency should conduct the analyses needed to project the numbers of data exchange transactions along with the frequency and nature of the data exchanges (that is, whether the transactions are batch or online, and how frequently they will be conducted) expected from its partners in the future.

Agency officials have recognized the need for a target architecture that addresses requirements for data exchanges. For example, in 2008, an SSA workgroup conducted an analysis to address management and technical issues related to its data exchanges, which was intended to support planning for its growing data exchange program.³⁵ Among other things, the workgroup recommended to the Commissioner of Social Security that the agency devote sufficient resources to develop a well-defined target architecture that is sufficiently scalable to meet the agency's future needs for supporting data exchanges.³⁶

However, while SSA has developed a target architecture describing applications and service components that are used to support the agency's business operations, according to the Directors of the Division of Information, Verification and Exchange Services, and of the Office of Strategic Services, the agency has not developed a target architecture that addresses specific business and technical requirements for supporting the

³⁴*Management of Federal Information Resources; DOD Architecture Framework, Version 1.5, Volume II* (Apr. 23, 2007).

³⁵This activity, called the Electronic Information Exchange Initiative, resulted in a report issued in September 2008, that included recommendations intended to help address challenges related to data exchange management and systems-related issues. Among other things, the workgroup found that there was no clear direction regarding the implementation of new technologies within the existing or a future data exchange environment, and that the agency did not have a clearly stated target architecture for data exchanges.

³⁶Although the Commissioner stated in December 2008 that the agency had established milestones for acting on these recommendations (the statement was in response to our recommendation that the Commissioner act on the Electronic Information Exchange Initiative recommendations; [GAO-09-126](#)), the agency's Director of the Division of Information, Verification and Exchange Services recently stated that while the EIEI report provided a significant amount of information pertaining to SSA's electronic data exchange activities, the recommendations no longer reflected the agency's current position. The official told us that the recommendations are being reassessed to determine which ones are viable in the agency's current and future operating environments.

agency's data exchange programs. Moreover, these directors stated that the current agencywide target architecture does not specifically address data exchanges with external organizations.

Lacking sound projections of future workloads, SSA will not be able to clearly define specific requirements for meeting the increasing demands on its data exchange environment. Moreover, without a target architecture that addresses specific requirements for supporting the agency's data exchange programs, the agency cannot be assured that its IT infrastructure will provide the resources and levels of service required to meet the future needs of its data exchange partners. Consequently, SSA's ability to continue to effectively and efficiently support its partners' future needs for electronic data exchange services could be jeopardized.

Conclusions

SSA's existing IT infrastructure effectively supports its current outgoing electronic data exchange environment and provides the agency's partners with data that support and enhance their abilities to carry out business operations. The state and federal partners included in our study experienced few or no problems associated with the agency's IT infrastructure. However, the agency and its partners anticipate that the demand for these exchanges will grow, and that the methods for conducting the exchanges will become more complex. Nonetheless, SSA has not performed the detailed analyses needed to project the workload and performance requirements of a future data exchange environment. While it has defined an agencywide target architecture, this architecture does not address specific business and technical requirements for supporting the agency's data exchange programs. Until it conducts these analyses, the agency will lack information essential to developing a target architecture for an IT infrastructure that effectively supports the ability of data exchange partners to carry out their business operations in the future.

Recommendations for Executive Action

To help ensure that SSA's IT infrastructure effectively supports the anticipated increase in demand for electronic data exchange services, we recommend that the Commissioner of Social Security direct the Associate Commissioner, Office of Earnings, Enumeration and Administrative Systems to

- conduct detailed analyses to determine workload projections and define requirements for effectively and efficiently delivering data exchange services to the agency's partners in the future and

-
- use the results of these analyses to update the agency's target architecture to address business and technical requirements of a future data exchange environment.

Agency Comments and Our Evaluation

The Commissioner of Social Security provided written comments on a draft of this report. In the comments, the agency agreed with our recommendations and stated that it would conduct detailed analyses to determine workload projections and define future requirements for delivering data exchange services as funding is available. Further, the Commissioner stated that it would use the results of the analyses to update the agency's target architecture to ensure that it addresses the business and technical requirements of a future data exchange environment. If these actions are taken, the agency should be better positioned to meet the growing needs of its data exchange partners.

SSA also provided technical comments, which we have incorporated into the report as appropriate. The agency's written comments are reproduced in appendix II.

As agreed with your office, unless you publicly announce its contents earlier, we plan no further distribution of this report until 30 days from the date of this letter. At that time, we will send copies of the report to interested congressional committees, the Commissioner of Social Security, and other interested parties. This report will also be available at no charge on our Web site at <http://www.gao.gov>.

Should you or your staff have questions on matters discussed in this report, please contact me at (202) 512-6304 or melvinv@gao.gov. Contact points for our Offices of Congressional Relations and Public Affairs may be found on the last page of this report. GAO staff who made major contributions to this report are listed in appendix III.

Sincerely yours,



Valerie C. Melvin
Director, Information Management
Human Capital Issues

Appendix I: Objectives, Scope, and Methodology

Our objectives were to (1) determine the extent to which the Social Security Administration's (SSA) information technology (IT) infrastructure effectively and efficiently supports its current data exchange programs, and describe any systems-related problems affecting the agency's data exchange partners and (2) describe SSA's efforts to ensure that its IT infrastructure can support the agency's and its partners' future data exchange environment.

To address both of these objectives, we focused our study on SSA's data exchanges that provide information to support state and other federal agencies' programs, and that affect partners' abilities to provide services to individuals—that is, “outgoing” data exchanges.¹ To determine whether SSA's existing IT infrastructure is effective in supporting the agency's data exchange programs, we first identified the components of the infrastructure that support the agency's data exchange programs. To do this, we obtained and analyzed agency documentation, such as internal management reports; spreadsheets describing data exchange programs, partners, and systems; descriptions of systems development and IT management processes; and descriptions of IT infrastructure components. To assess the reliability of the data provided by SSA, we held discussions with agency officials who were knowledgeable about the agency's data exchange infrastructure and determined that the data were sufficiently reliable for the purposes of our engagement.

From our assessment of this information, we identified and selected systems that are key to enabling the exchange of electronic data—that is, those that support the largest number of outgoing data exchanges, are used by the most partners, and process the largest number of data requests. We verified our selection through discussions with the Director, Division of Information, Verification and Exchange Services. We held discussions with additional agency officials, including the Associate Commissioner, Office of Earnings, Enumeration and Administrative Systems; Associate Commissioner, Office of Systems, Electronic Services; Assistant Associate Commissioner, Office of Telecommunications and Systems Operations; Director, Office of Systems Security Operations Management; Director, Office of Electronic Information Exchange; and Director, Office of Strategic Services. We also reviewed documentation describing the agency's plans to make improvements to its IT

¹SSA also provides data, such as Social Security Number verification, to other external entities, such as private companies. The scope of our work did not include those partners.

infrastructure and discussed these plans with agency officials. Additionally, we interviewed state and federal data exchange partners to obtain their views on the ability of SSA's IT infrastructure to provide data that support their business operations.

To determine the extent to which systems-related problems exist and affect SSA's data exchange partners and their ability to carry out business operations, and how the agency resolves these problems, we selected and obtained the views of partners from multiple agencies in five states, a third-party consortium that represents states and territories that participate in two of SSA's data exchange programs, and four federal agency partners. Together, these state and federal partners represented 24 programs that are supported by SSA's data exchanges. Our criteria and methodology for selecting these partners are described later in this appendix. We discussed with these partners their experiences with SSA's data exchanges, including the extent to which their ability to conduct business operations are affected by systems-related problems associated with the agency's IT infrastructure. We reviewed and assessed documentation provided to us that described the types of systems-related problems that partners encountered in exchanging data. We also interviewed two SSA regional office data exchange coordinators to discuss any systems-related problems identified or reported to them by the partners they support, and to obtain information about programs that together fully utilize the IT infrastructure components that support the data exchange environment.

To describe SSA's efforts to ensure that its IT infrastructure can support the agency's and its partners' future data exchange environment, we held discussions with the agency officials and state and federal partners that we have previously described and examined data provided by SSA that illustrated increased transaction volume from 2007 to 2008. We also obtained and reviewed documentation that described increased requests for online access to certain data exchange systems over the past 24 months. Additionally, we reviewed relevant SSA strategic planning documents, including its IT strategic plan and vision document to identify plans related specifically to data exchanges.² We assessed these plans to identify activities specifically related to data exchanges and to determine the extent to which they addressed projected data exchange workloads

²Social Security Administration, *Social Security Information Resources Management Strategic Plan, Fiscal Year 2007*; and *Information Technology Vision, 2009–2014*.

and the IT resource requirements for efficiently and effectively supporting future requirements. In addition, we interviewed SSA officials and data exchange stakeholders familiar with the agency's data exchange programs to identify the agency's plans for addressing future data exchange workloads, including ensuring that its IT infrastructure can adequately support future demands for outgoing data exchanges to other federal and state agencies.

We confirmed the information gathered from SSA's regional data exchange coordinators and systems officials by corroborating it with selected other state and federal exchange partners. We determined that the information gathered was sufficiently reliable for the purposes of our review. Further, at the conclusion of our study in September 2009, we validated the examples of state and federal agencies' experiences with SSA's data exchanges with officials from those agencies.

Method for Selecting Data Exchange Partners

To select state and federal data exchange partners for this study, we identified a nonprobability sample based on our review of information provided by agency officials that listed and described all of the data exchange programs supported by SSA. From the list provided by the agency, we identified 814 outgoing data exchanges—those through which SSA provides data to state and other federal agencies. Of these exchanges, we identified 663 that provide SSA data to agencies in all 50 states, the District of Columbia, and 4 territories (American Samoa, American Virgin Islands, Guam, and Puerto Rico), and 83 that provide data to 16 federal agencies.

From the 50 states, we selected 5 states based on the number of SSA data exchange programs in which they participate and the types of state programs the exchanges support (e.g., driver's license issuance, voter registration, unemployment benefits administration, social services administration, and other programs). In selecting the 5 states, we identified 2 states that participated in the most data exchanges, 1 state that participated in an intermediate number of exchanges, and 2 states that participated in the fewest data exchanges.

- The 2 states participating in the most data exchanges were New York and California (25 and 19 data exchanges, respectively).
- The 1 state we selected with the intermediate number of data exchanges was Idaho (12 data exchanges).

- The 2 states participating in the fewest data exchanges were North Carolina and Iowa (10 and 9 data exchanges, respectively).

We held discussions with officials from each of the states' agencies that receive data through SSA's data exchange programs to obtain information about any systems-related problems they may have experienced and the actions taken by SSA to resolve problems. Table 6 shows the states and agencies within those states that we contacted.

Table 6: States and Agencies That We Contacted

States	Agencies
New York	Six programs under the Office of Temporary and Disability Assistance: <ul style="list-style-type: none"> • Family Assistance • Emergency Assistance to Families • Home Energy Assistance • Food Stamps • Temporary Assistance to Needy Families • Medicaid
California	State Controller's Office Employment Development Department Franchise Tax Board Health Care Services Social Services Board of Equalization Department of Motor Vehicles Child Support Services
Iowa	Department of Human Services Department of Transportation
North Carolina	Board of Elections Employment Security Commission
Idaho	Department of Motor Vehicles Department of Labor Department of Human Services

Source: GAO.

We also held discussions with SSA's major stakeholder user group organization—the American Association of Motor Vehicle Administrators (AAMVA)—which provides data exchange support to state driver's licensing administrations and supports voter registration through the Help America Vote Verification system. We contacted chief information officers from each of the five selected states and AAMVA to obtain contact

information for the officials responsible for the programs and systems that receive electronic data through participation in SSA's data exchange programs.

We based our selection of federal data exchange partners on the scope and impact of the agencies' programs supported by SSA's data exchanges on the country's population, including veterans' programs beneficiaries, government and private employers, U.S. passport holders and applicants, U.S. tax filers, and Medicare beneficiaries. We held discussions with agency officials regarding the following federal programs to obtain information about their experiences with SSA's data exchange programs and the systems that support them:

- the Department of Veteran Affairs, Veterans Benefits Administration's benefits and insurance programs, and the Veterans Health Administration health care administration program;
- the Department of Homeland Security employment eligibility program;
- the Department of State's passport verification and foreign service retiree benefit payment programs; and
- the Department of Health and Human Services, Centers for Medicare and Medicaid Services' Medicare benefits administration program.

Since we selected a nonprobability sample, the information obtained through discussions with the selected state and federal data exchange partners is not generalizable across the entire population of SSA's data exchange partners.

Appendix II: Comments from the Social Security Administration



SOCIAL SECURITY

The Commissioner

September 9, 2009

Ms. Valerie C. Melvin
Director, Information Management
and Human Capital Issues
U.S. Government Accountability Office
441 G Street, NW
Washington, D.C. 20548

Dear Ms. Melvin:

Thank you for the opportunity to review and comment on the Government Accountability Office (GAO) draft report, "INFORMATION TECHNOLOGY: Social Security Administration's Data Exchanges Support Current Programs, but Better Planning Needed to Meet Future Demands" (GAO-PUB No. 09-966). Our comments on the report are attached.

If you have any questions, please contact me or have your staff contact Candace Skurnik, Director, Audit Management and Liaison Staff at (410) 965-4636.

Sincerely,

A handwritten signature in black ink, appearing to read "Michael J. Astrue".

Michael J. Astrue

Enclosure

SOCIAL SECURITY ADMINISTRATION BALTIMORE MD 21235-0001

COMMENTS ON THE GOVERNMENT ACCOUNTABILITY OFFICE DRAFT REPORT, "INFORMATION TECHNOLOGY: SOCIAL SECURITY ADMINISTRATION'S DATA EXCHANGES SUPPORT CURRENT PROGRAMS, BUT BETTER PLANNING NEEDED TO MEET FUTURE DEMANDS" (GAO-PUB NO. 09-966)

Recommendation 1

Conduct detailed analyses to determine workload projections and define requirements for effectively and efficiently delivering data exchange services to our partners in the future.

Comment

We agree. We will conduct detailed analyses to determine workload projections and define requirements for effectively and efficiently delivering data exchange services to our partners in the future, as funding is available.

We routinely conduct analyses to determine workload projections and requirements. However, we do not have a separate portfolio for data exchanges in our information technology (IT) planning process. We plan for data exchanges that are program related in the context of the line of business that the exchange supports (e.g., Medicare). We plan reimbursable exchanges (e.g., E-Verify) outside of the IT planning process. Reimbursable exchanges are nonetheless, subject to the rigor and discipline of our systems development process.

Recommendation 2

Use the results of these analyses to update our target architecture to address business and technical requirements of a future data exchange environment.

Comment

We agree. We will use the results of our analyses to update our target architecture to address business and technical requirements of a future data exchange environment, as funding becomes available.

Appendix III: GAO Contact and Staff Acknowledgments

GAO Contact

Valerie C. Melvin, (202) 512-6304 or melvinv@gao.gov

Staff Acknowledgments

In addition to the contact named above, key contributions to this report were also made by Teresa F. Tucker, Assistant Director; Michael A. Alexander; Tonia B. Brown; Barbara S. Collier; Rebecca E. Eyler; Neil J. Doherty; Nancy E. Glover; Jacquelyn K. Mai; Lee A. McCracken; Thomas E. Murphy; Madhav S. Panwar; and Brandon S. Pettis.

GAO's Mission

The Government Accountability Office, the audit, evaluation, and investigative arm of Congress, exists to support Congress in meeting its constitutional responsibilities and to help improve the performance and accountability of the federal government for the American people. GAO examines the use of public funds; evaluates federal programs and policies; and provides analyses, recommendations, and other assistance to help Congress make informed oversight, policy, and funding decisions. GAO's commitment to good government is reflected in its core values of accountability, integrity, and reliability.

Obtaining Copies of GAO Reports and Testimony

The fastest and easiest way to obtain copies of GAO documents at no cost is through GAO's Web site (www.gao.gov). Each weekday afternoon, GAO posts on its Web site newly released reports, testimony, and correspondence. To have GAO e-mail you a list of newly posted products, go to www.gao.gov and select "E-mail Updates."

Order by Phone

The price of each GAO publication reflects GAO's actual cost of production and distribution and depends on the number of pages in the publication and whether the publication is printed in color or black and white. Pricing and ordering information is posted on GAO's Web site, <http://www.gao.gov/ordering.htm>.

Place orders by calling (202) 512-6000, toll free (866) 801-7077, or TDD (202) 512-2537.

Orders may be paid for using American Express, Discover Card, MasterCard, Visa, check, or money order. Call for additional information.

To Report Fraud, Waste, and Abuse in Federal Programs

Contact:

Web site: www.gao.gov/fraudnet/fraudnet.htm

E-mail: fraudnet@gao.gov

Automated answering system: (800) 424-5454 or (202) 512-7470

Congressional Relations

Ralph Dawn, Managing Director, dawnr@gao.gov, (202) 512-4400
U.S. Government Accountability Office, 441 G Street NW, Room 7125
Washington, DC 20548

Public Affairs

Chuck Young, Managing Director, youngc1@gao.gov, (202) 512-4800
U.S. Government Accountability Office, 441 G Street NW, Room 7149
Washington, DC 20548

